

# AGM Battery For passenger vehicles

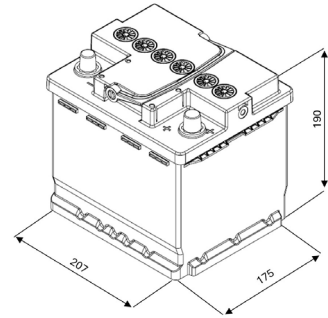

## Part information

Part No:	0092S5A010
Short code:	S5A01
Product line:	S5A
Technology:	AGM - Absorbent Glass Mat*
EAN code:	4047026937558



## Technical information

Nominal Voltage:	12 V			
Nominal capacity: (20 hr discharge down to 10.5 V)	C20	50 Ah		
Reserve capacity: (@ 25 A)				
Cold cranking amps: (EN / -18°C U10s ≥ 7.5 V)	540 A			
Group size:	LN1			
JIS type:	-			
Short-time angle of inclination:	360°			
Permanent angle of inclination:	up to 90°			
Dimension:	Length	Width	Ht. w/o terminal	Ht. w terminal
	207 mm	175 mm		190 mm
Total battery weight: (approx., filled battery)	15,16 kg			
Layout: (ETN, DIN 72331)	0			
Terminal: (ETN, DIN 72331)	1			
Base hold down: (ETN, DIN 72331)	B13			
Degassing:	VRLA (Valve Regulated Lead Acid)			

## Technical data

Application:	Start/Stop		
Service:	Maintenance-free		
Standard charging:	Charging voltage:	14,8 V	
	Charging current:	5 A	
	Charging pattern:	IU	
European standards:	DIN EN 60095-1, -2, -4 Lead-acid starter batteries; DIN EN 50342 Lead-acid starter batteries; DIN 41 773, Charger with IU characteristics		

\*AGM (Absorbent Glass Mat): acid absorbed by micro-fiberglass mats allow higher amounts of energy to be provided