

EFB Battery For passenger vehicles

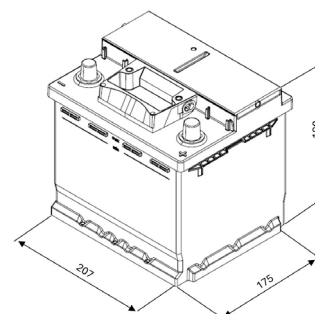

Part information

Part No:	0092S4E020
Short code:	S4E02
Product line:	S4E
Technology:	EFB - Enhanced Flooded Battery*
EAN code:	4047026937534



Technical information

Nominal Voltage:	12 V			
Nominal capacity: (20 hr discharge down to 10.5 V)	C20	50 Ah		
Reserve capacity: (@ 25 A)				
Cold cranking amps: (EN / -18°C U10s ≥ 7.5 V)	550 A			
Group size:	LN1			
JIS type:	-			
Short-time angle of inclination:	55°			
Permanent angle of inclination:	0°			
Dimension:	Length 207 mm	Width 175 mm	Ht. w/o terminal	Ht. w terminal 190 mm
Total battery weight: (approx., filled battery)	14,57 kg			
Layout: (ETN, DIN 72331)	0			
Terminal: (ETN, DIN 72331)	1			
Base hold down: (ETN, DIN 72331)	B13			
Degassing:	Central			

Technical data

Application:	Start/Stop		
Service:	Maintenance-free		
Standard charging:	Charging voltage:	14,4 V	
	Charging current:	5 A	
	Charging pattern:	IU	
European standards:	DIN EN 60095-1, -2, -4 Lead-acid starter batteries; DIN EN 50342 Lead-acid starter batteries; DIN 41 773, Charger with IU characteristics		

* EFB (Enhanced Flooded Battery): the positive plate is coated with a polyester scrim, thus keeping the self-discharge rates low